

1. Attach plastic feet to the uprights
2. Attach single shelf carrier at the top and a double at the bottom of the frame. Push in lugs with a flathead screwdriver to secure.
3. Attach the remaining double shelf carriers at the desired heights within the bay.
4. Insert the panels into the top and bottom shelf carriers to stabilise the bay.
5. Attach the cross bracing at the back of the bay using the expo spanner + 8mm spanner.
6. Insert the rest of the shelf panels to complete the bay.
7. To add an extension bay, follow steps 1 - 3 with one frame, attach shelf carriers to the outside of the existing bay. Then repeat steps 4 and 6.

### Expo 3 Shelf Capacities

Width (mm)	Depth (mm)					
	200	300	400	500	600	800
700	90kg	135kg	180kg	225kg	270kg	300kg
1000	70kg	105kg	140kg	175kg	210kg	280kg
1150	80kg	120kg	160kg	200kg	240kg	300kg
1300	70kg	105kg	140kg	175kg	210kg	280kg

### Tools Required

Rubber Mallet, Flat Head Screw Driver  
Expo Spanner (included), Spanner 8mm

### Safety Precaution

Two competent people wearing safety gloves, safety shoes and protective eyewear are recommended to undertake the assembly.

## Expo H Bracing Installation

H Brace is used instead of the standard Cross Brace on both Expo 3 or Expo 4 bays to allow access from all sides. The standard Cross Brace 'obstructs' the back of the bay so loading is only possible from the front (and sides), while the H brace, attached at the shelf level, allows access from both the front and back (and sides) of the bay.

**1.** Build the first Expo bay and also install all shelves at desired heights as per the original Expo Assembly Instructions - excluding the Cross Brace installation step. The bay should be supported by another person or leaned against a wall while building it.

**2.** Install first H Brace to the front of the bay at the height of the second shelf from the bottom. Use the M6x15 nuts and bolts to fix the H brace to the uprights - locate the right 2 holes on the H brace matching the holes on the uprights - depending on the shelf height, they might be at a different position. One hole should be above the shelf level and the other below the shelf level.

**3.** Install the second H brace to the back of the bay, the same way as the first one, but position it to the second shelf from top of the bay.

If you are building a run of Expo bays, please refer to the bracing diagram below. To see how to build a run of Expo bays, please refer to the original Assembly Instructions that came with your particular Expo system.

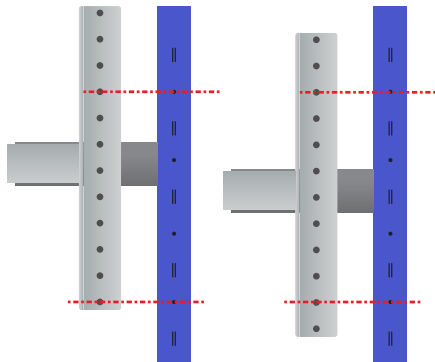
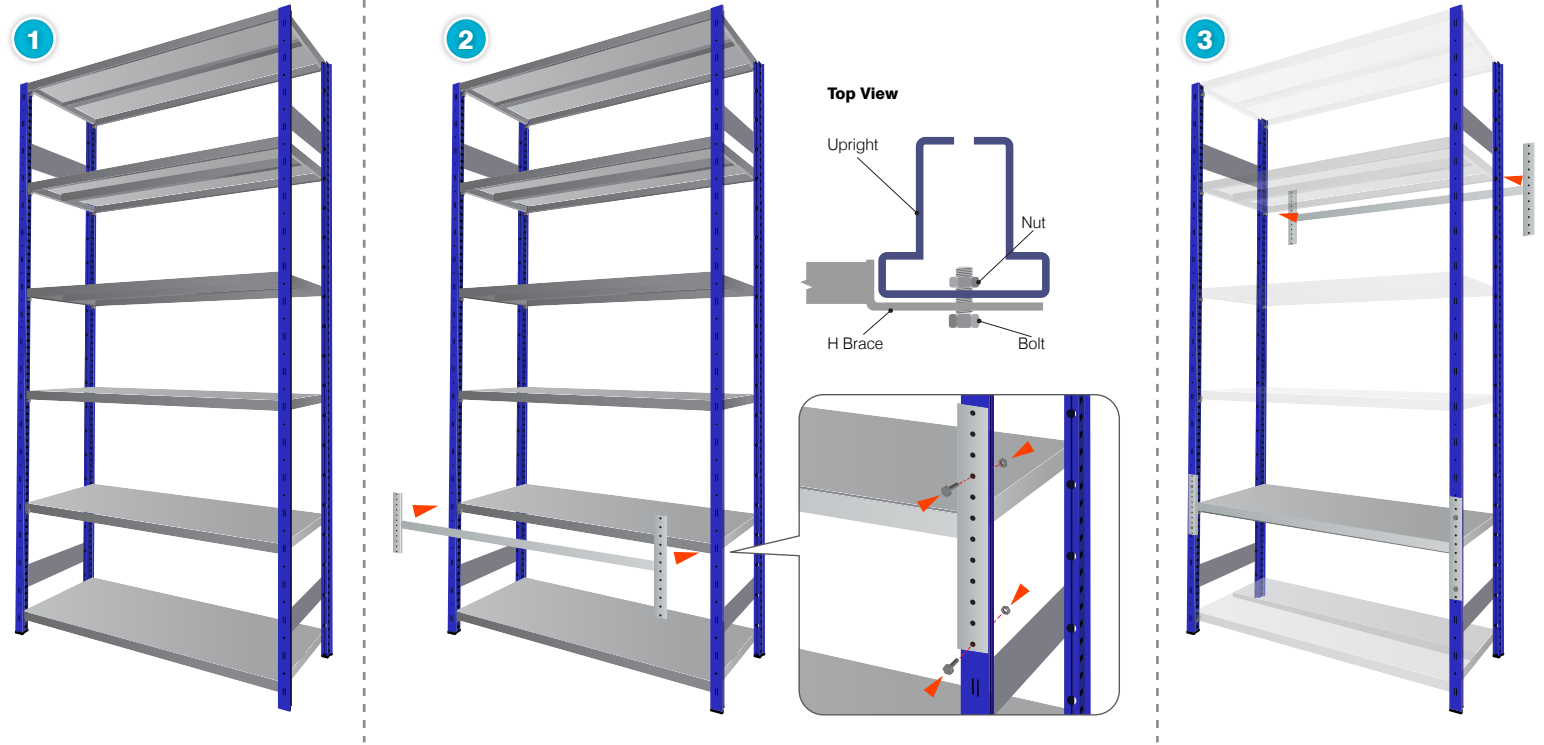

Picture above shows how the position for bolts might differ depending on the shelf position. (example only)

**Bracing Diagram for a run of Expo bays using H Braces**

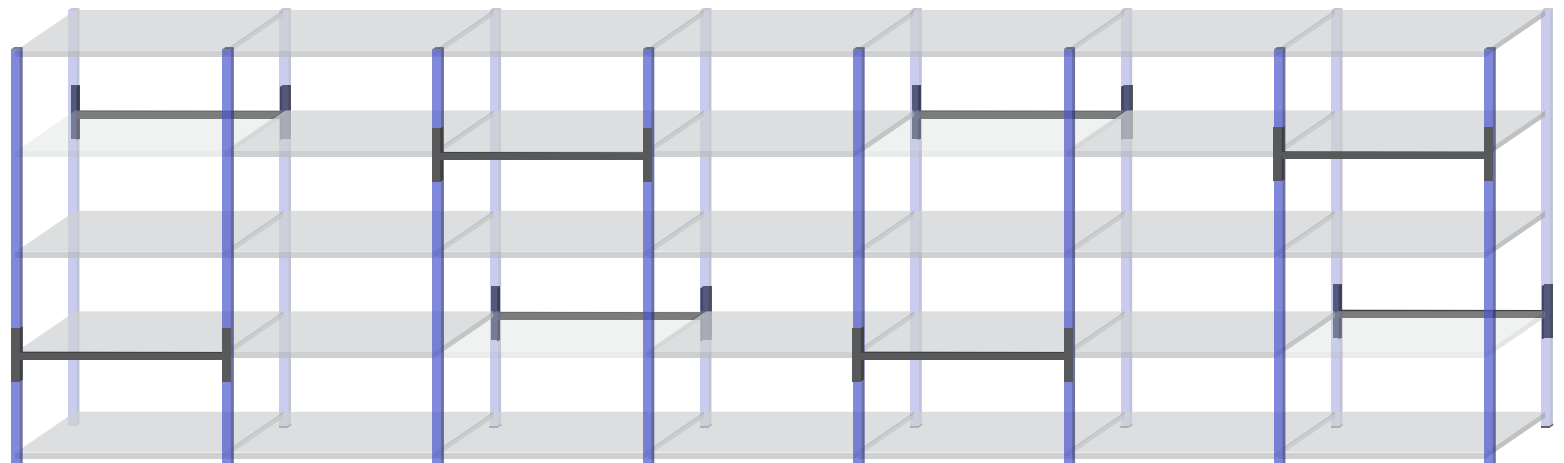

### Tools Required



Expo Spanner (included)

## Side Cladding Installation

Side Cladding is installed in the first part of the bay assembly, when two uprights are connected either by battens (expo 4) or shelf carriers (expo3) with feet attached - so you have completed step 2 on the bay assembly instructions.

1. Lean the connected frame to the side and slide in the first steel sheet clad in between the uprights inner gaps.
2. Attach plastic joining rib to the top of the first steel sheet clad.
3. Slide in another steel sheet clad panel the same way as the first one to sit in the ridge of the joining rib.
4. Once all frames requiring side cladding are assembled, continue building the bay as described on the bay assembly instructions - step 3 and onwards.

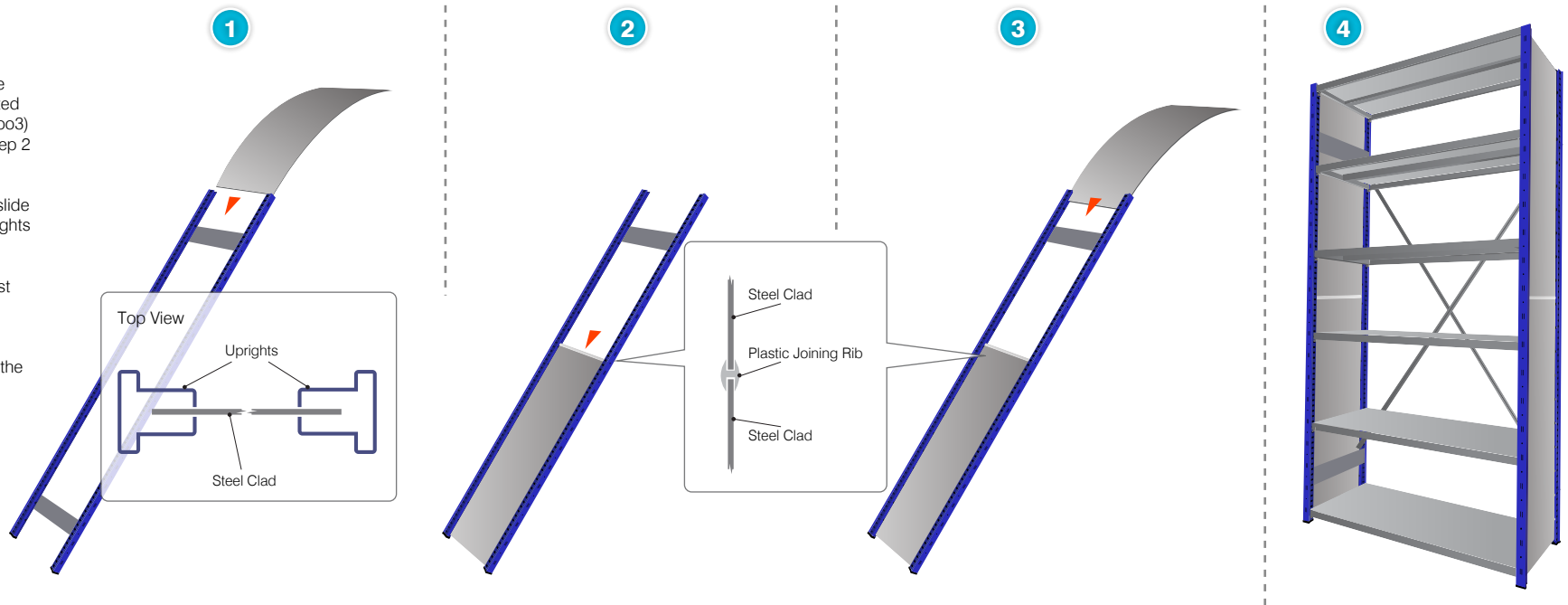

## Mesh Side Panel Installation

Mesh Side panels can be attached at any time after the bay has been assembled.

1. Insert the Cable tie into the upright's inner gap via the 13mm diameter hole.
2. Position the mesh as required and loop the tie around the outer wire of the mesh.
3. Repeat the process along the whole height of the bay and on both sides of the mesh. Use as many ties as required - approx 2-3 ties per meter per side.
4. Install all the additional mesh as required.

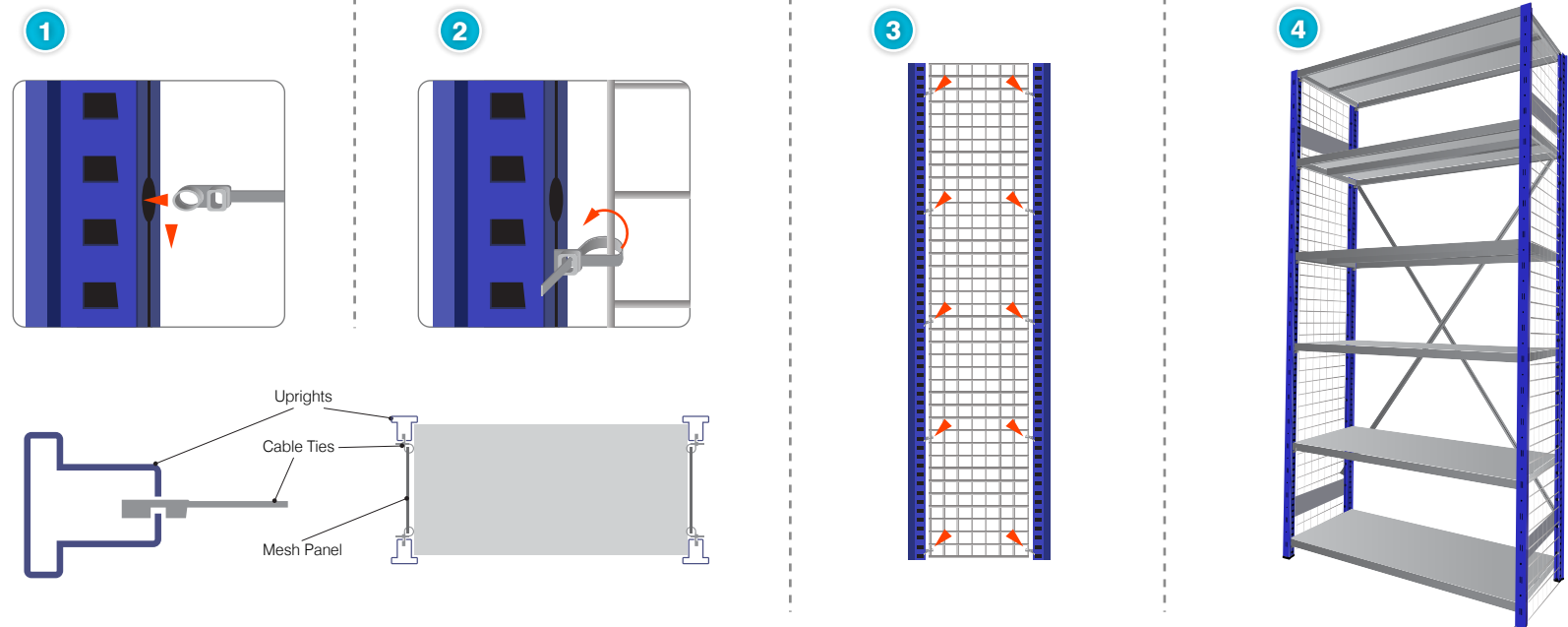

## Back Mesh Panel Installation

Mesh back panels can be attached at any time after the bay has been assembled.

1. Push the arrow tip of the cable tie through the hole on the back of the upright.
2. Position the mesh as required and loop the tie around the outer wire of the mesh.
3. Repeat the process along the whole height of the bay and on both sides of the mesh. Use as many ties as required - approx 2-3 ties per meter per side. To cover the whole back of the bay, you will need to use 2 or more mesh panels and use basic cable ties to join the panels together.
4. To prevent goods falling off at the back behind the shelf and the mesh, push the black clip onto the edge of the shelf and run through another cable tie to connect the clip and the back mesh. Use the clip on every 2nd shelf.

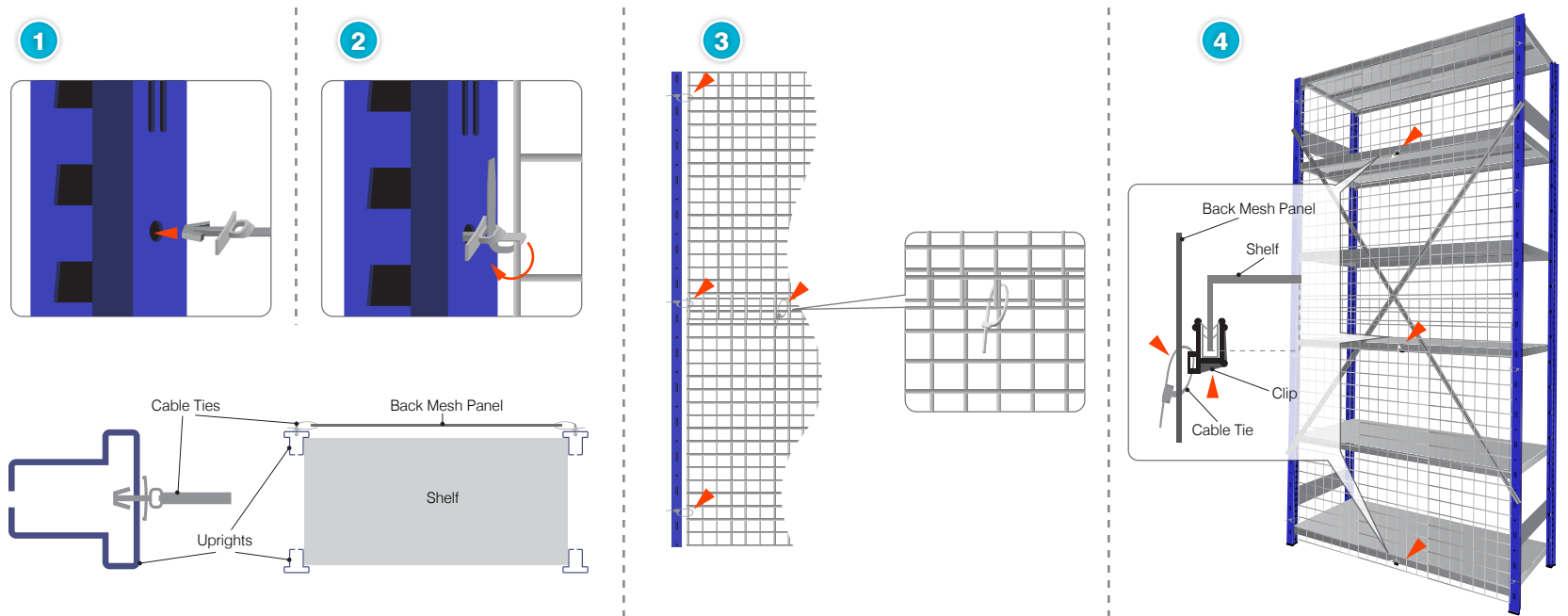

## Hook-in Back Cladding Installation

Depending on the height of the bay, use a combination of 400 and 500 mm tall panels. Do not use any bracing on bays with hook-in back cladding.

1. Place the first back cladding panel to the back of the bay by inserting the hooks on the panel to the vertical slots at the back of each upright. The first panel is situated 100mm off the floor.
2. Continue placing the other panels from the bottom up, on top of each other.
3. Insert the U Clip to both uprights just above the top hook of the top back panel to prevent the panels being accidentally knocked out.

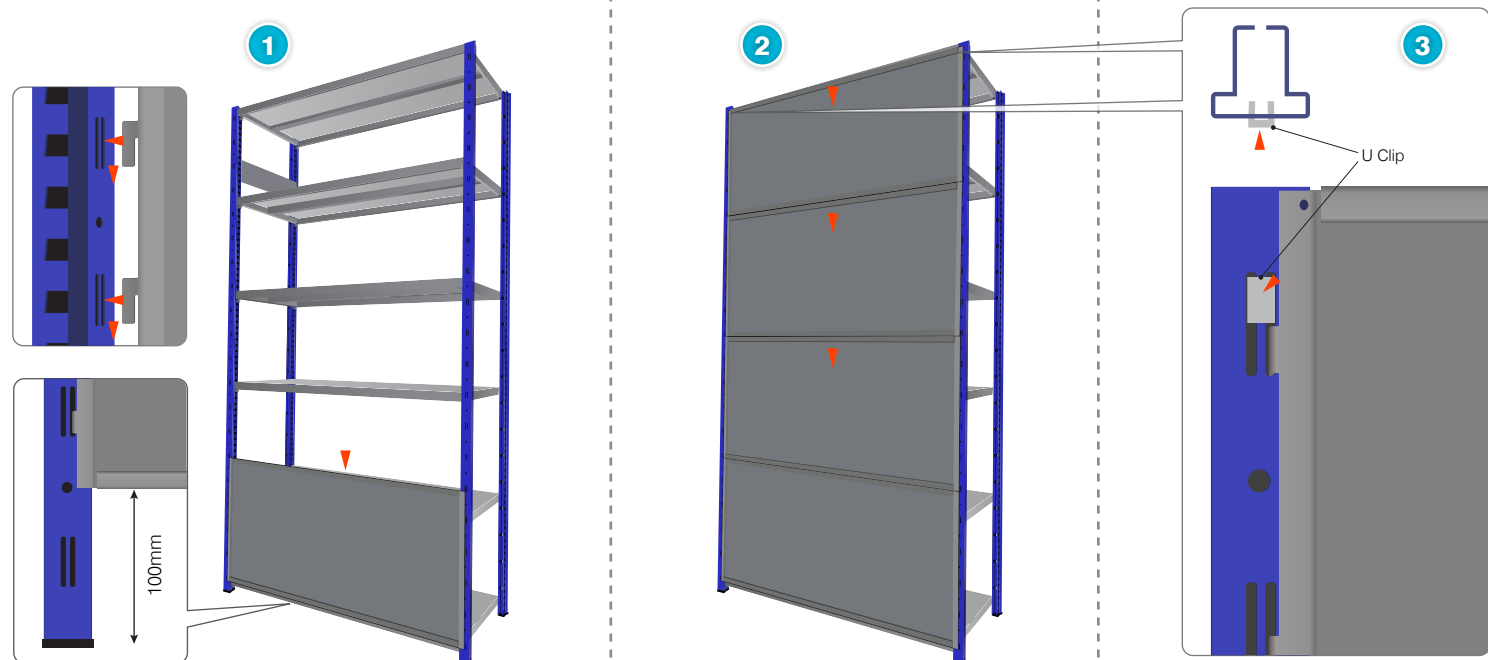



Build an Expo 3 or Expo 4 bay or a run of bays as you require. (please refer to specific assembly instructions to build the bays) No bracing is needed as the back cladding will brace the bays!

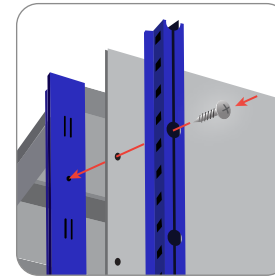
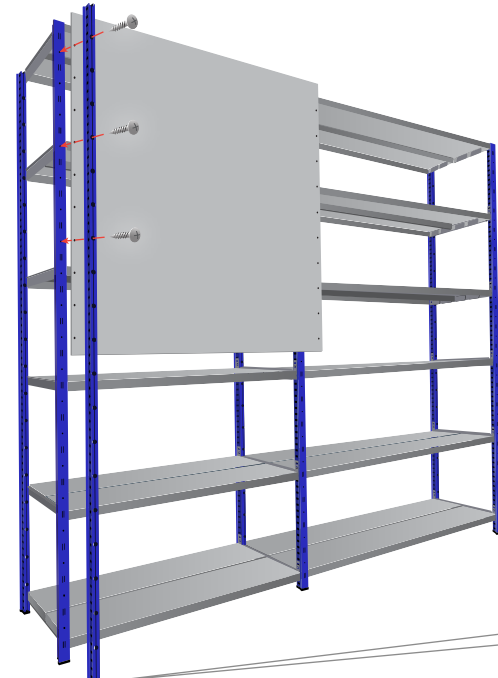

Please check the diagram on the next page before installation to see which positions to use to fix the cladding.

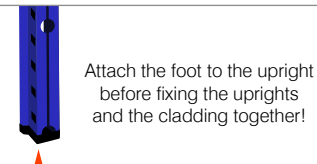

Attach the foot to the upright before fixing the uprights and the cladding together!

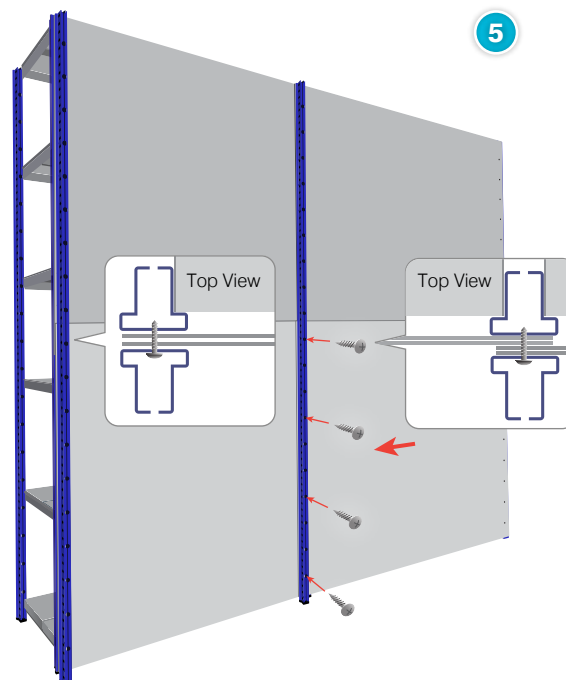
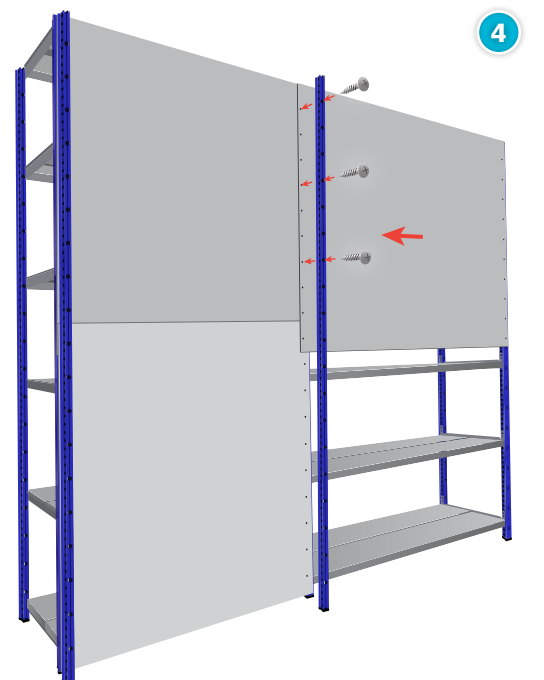
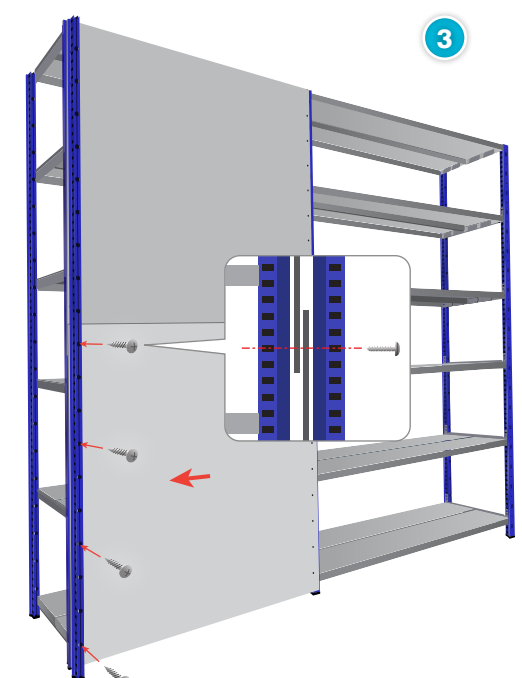

## 2. Check the diagram on the next page before installation

Attach the left side of the top piece of cladding (together with the first upright of the connecting bay) to the top hole of the first upright on the bay by fixing it using 'the screw' and screwdriver.

Do not tighten the screws at this stage, use the diagram on the next page to locate the positions for other screws. (If this is a single bay, you can fix the right side of the cladding together with the upright for the connecting bay to the second upright now)

3. Slide the lower cladding sheet between the uprights and attach to the upright overlapping the clad above by fixing it with the screws as shown on the screw positions diagram.

4. Attach the next top cladding sheet to the upright on the extension bay together with the next upright for the connecting bay, overlapping the previous piece of top cladding sheet. Secure using 'the screws' as per the screw positions diagram.

5. Now slide-in the next lower cladding sheet between the uprights and attach to the upright overlapping the previously placed cladding sheets by fixing it with 'the screws' as shown on the diagram.

**If you have more than 2 bays in the run, repeat the process from step 4. Otherwise continue on the next page**

## Tools Required

Pozi Screwdriver or as a Drill Bit on a Drill



6

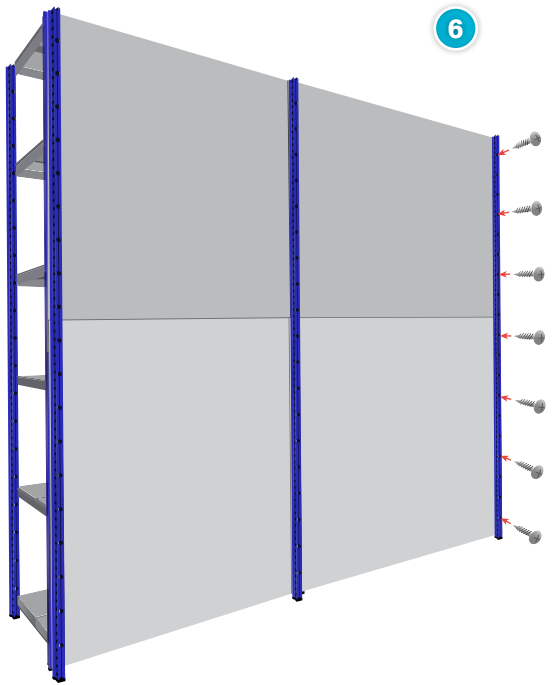

**6.** Finish the cladding of the run by attaching the last upright.  
Once your back cladding with uprights are in place, make sure the bay is square and tighten all loose screws.

**7.** Build the frames for the connecting bay. Refer to the assembly instructions for the particular system you are building.

- Expo 3 uses shelf carriers to connect the uprights into frames
- Expo 4 uses battens to connect the uprights into frames

**8.** Install the shelves. Refer to the assembly instructions for the particular system you are building.

- Expo 3 shelves are inserted into shelf carriers
- Expo 4 shelves are connected using shelf clips

7

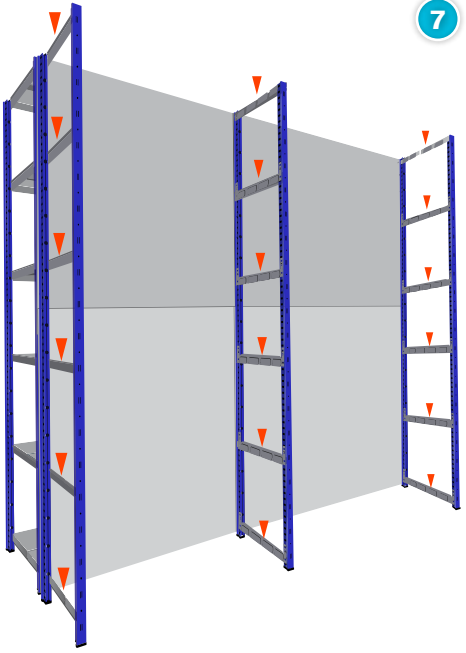

8

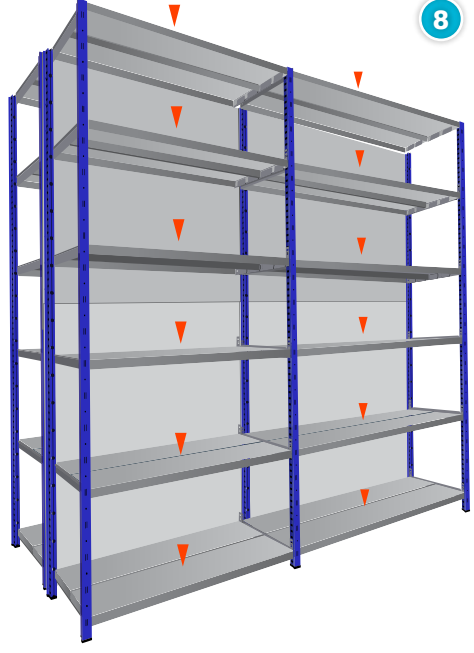

**Diagram - Screw Positions for Solid Steel Cladding on Expo Upright**

- ▶ ● ● Position where the screw connects the clad sheet with the upright
  - ▶ ● ● Same as above + the two clad sheets (or four clad sheets on an extension bay) overlap here
  - ▶ Position to be kept without screw
- Long section The side of the clad sheet where the first hole is further from the edge than on the other side. Make sure the long section is at the right side (top or bottom) when installing the cladding.

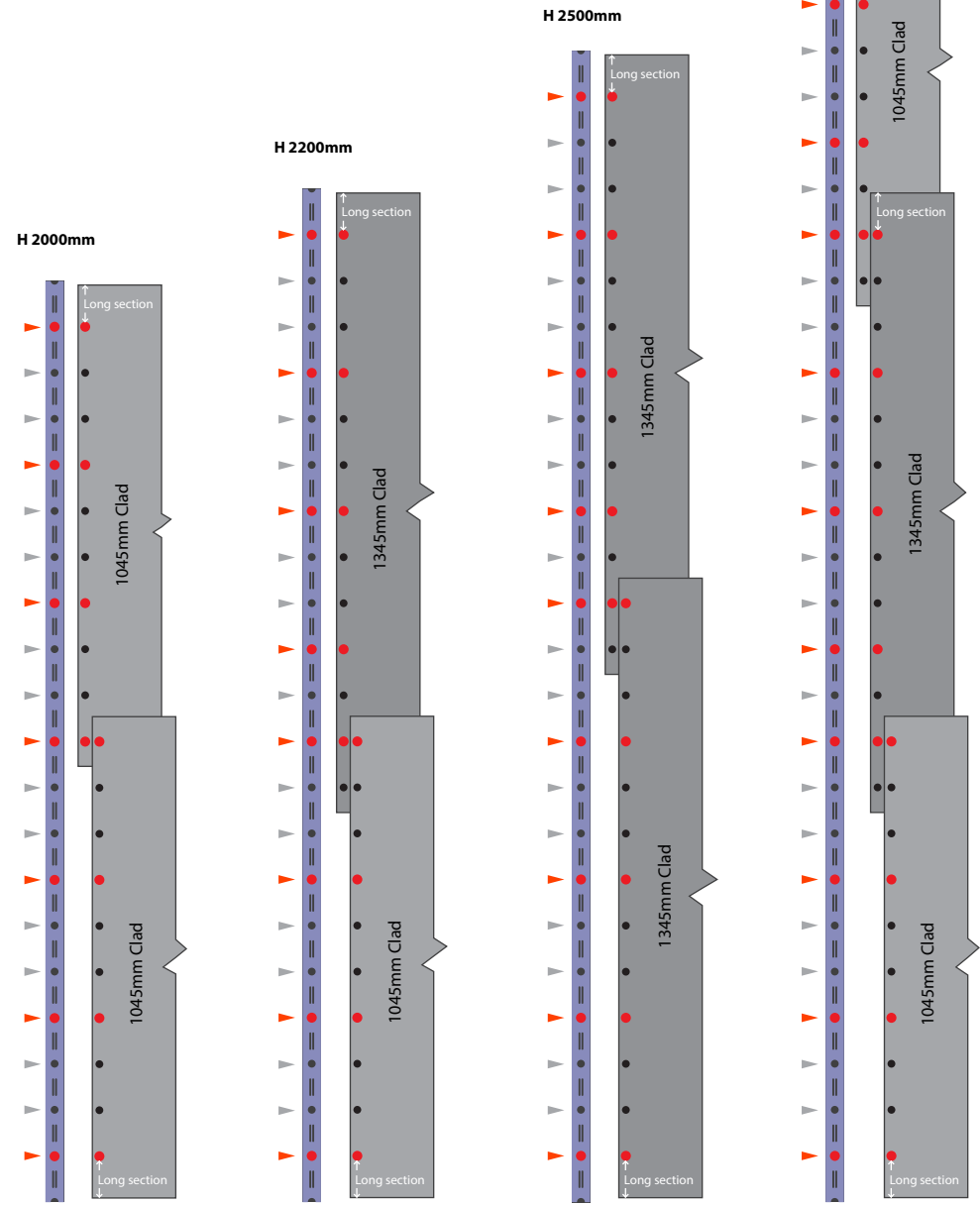



Build Expo 3 or Expo 4 bay or a run of bays as you require.  
(please refer to specific assembly instructions to build the bays)  
No bracing is needed as the cladding will brace the bays!

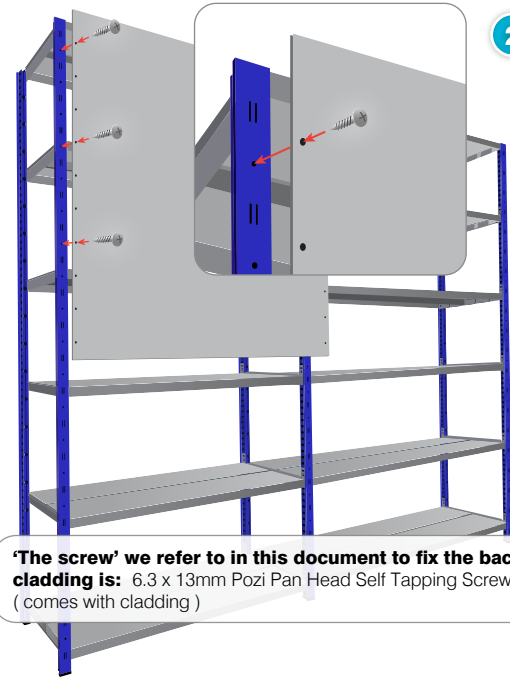

**'The screw' we refer to in this document to fix the back cladding is:** 6.3 x 13mm Pozi Pan Head Self Tapping Screw ( comes with cladding )

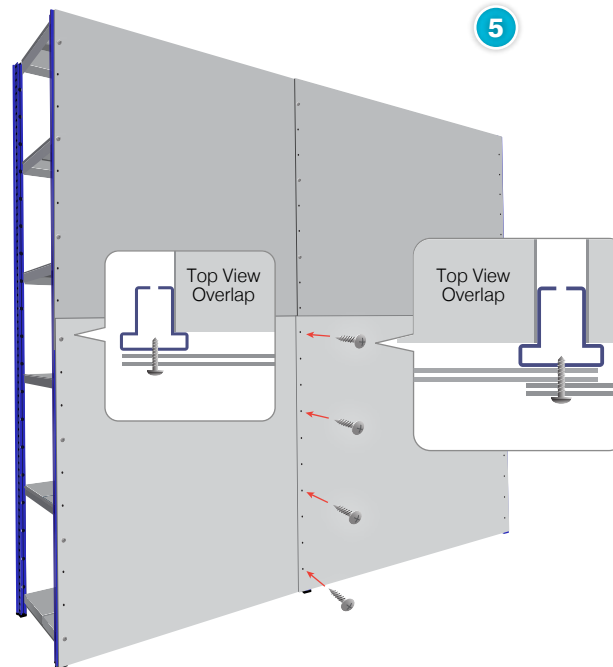
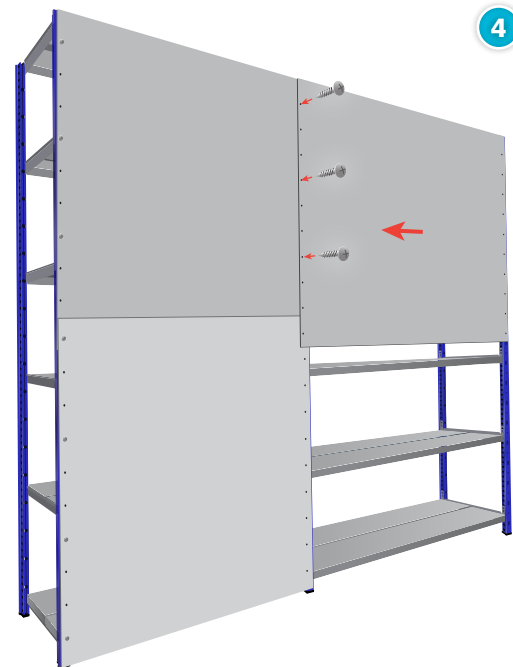
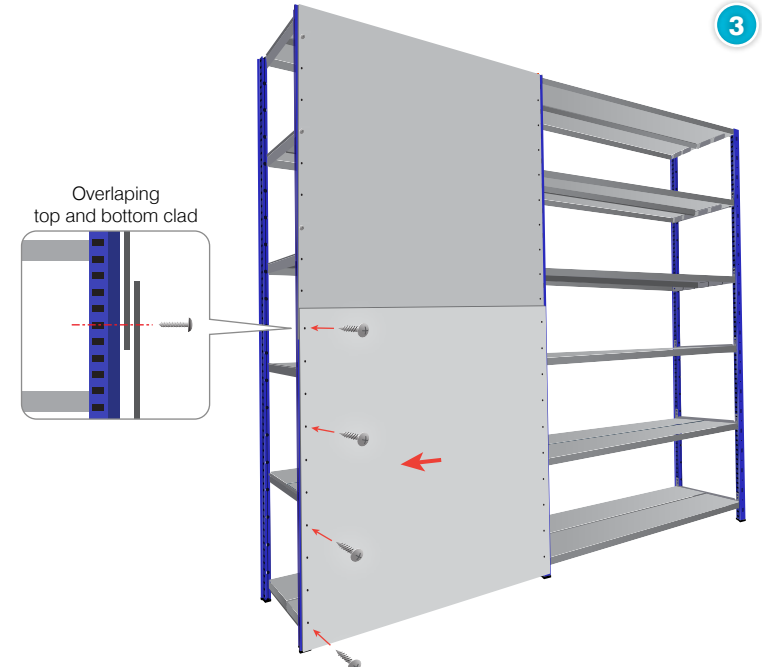

## 2. Check the diagram on the next page before installation

Attach the left side of the top piece of cladding to the top hole of the first upright on the bay by fixing it using 'the screw' and screwdriver. Do not tighten the screws at this stage, use the diagram on the next page to locate the positions for other screws.  
(If this is a single bay, you can fix the right side of the clad to the second upright now)

3. Attach the lower cladding sheet to the upright overlapping the clad above by fixing it with the screws as shown on the screw positions diagram.

4. Attach the next top cladding sheet to the upright on the extension bay, overlapping the previous piece of top cladding. Secure using 'the screws' as per the screw positions diagram.

5. Now attach the next lower cladding sheet to the upright, overlapping the previously placed cladding by fixing it with 'the screws' as shown on the screw positions diagram.

**If you have more than 2 bays in the run, repeat the process from step 4.**

### Tools Required

Pozi Screwdriver or as a Drill Bit on a Drill

### Safety Precaution

**Two competent people** wearing **safety gloves**, **safety shoes** and **protective eyewear** are recommended to undertake the assembly.

6

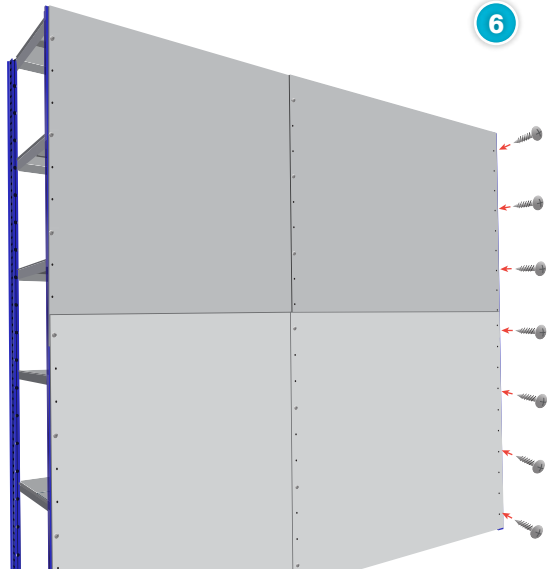

Finish the cladding of the run of bays by fixing the right side of the last clad sheets to the last upright of the run.

Once your back cladding with uprights are in place, make sure the bay is square and tighten all loose screws.



### Diagram - Screw Positions for Solid Steel Cladding on Expo Upright

- ▶ ● ● Position where the screw connects the clad sheet with the upright
- ▶ ● ● Same as above + the two clad sheets (or four clad sheets on an extension bay) overlap here
- ▶ Position to be kept without screw
- Long section The side of the clad sheet where the first hole is further from the edge than on the other side. Make sure the long section is at the right side (top or bottom) when installing the cladding.

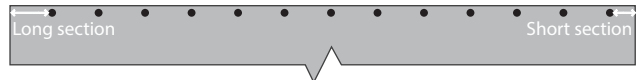

H 2000mm

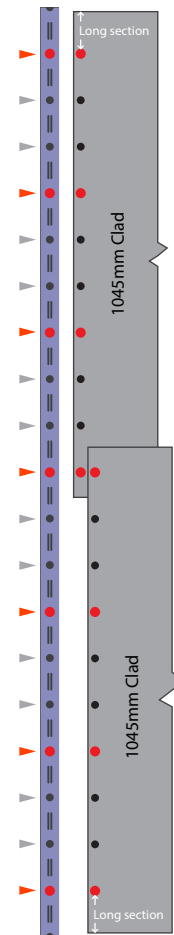

H 2200mm

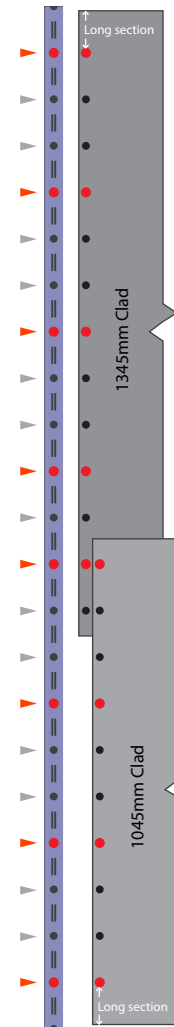

H 2500mm

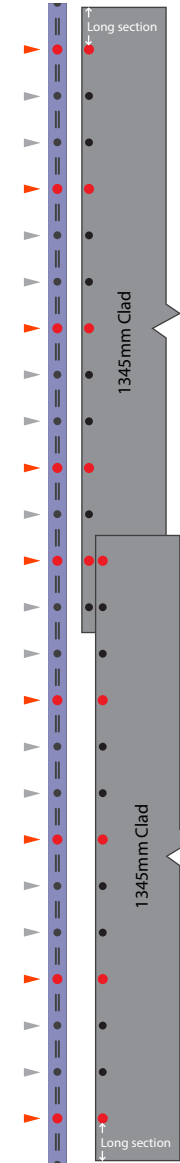

H 3000mm

