



Nomad

Nomad



Nomad specifying guide

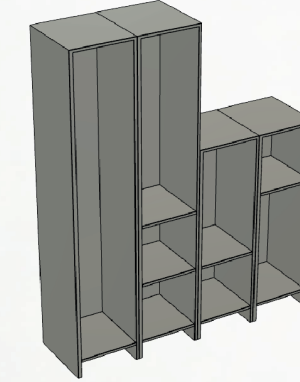
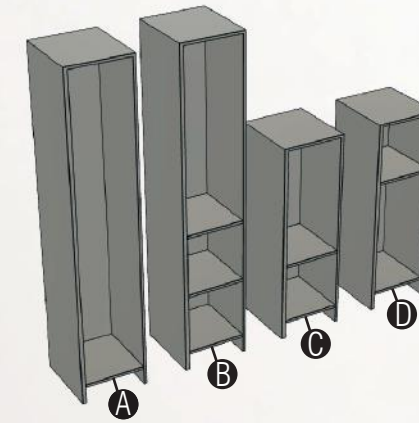

Step 1 Specify carcasses

Please note that the schematic opposite the carcassing pages indicates the location of fixed shelves. Adjustable shelves can be purchased separately (SLK-1AS-XXX)

Shown (left to right)

A	1 qty	SLK-5HC-WXR
B	1 qty	SLK-5HC-MXR
C	1 qty	SLK-3HC-BXR
D	1 qty	SLK-3HC-DXR

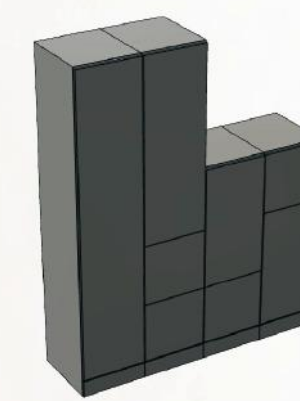
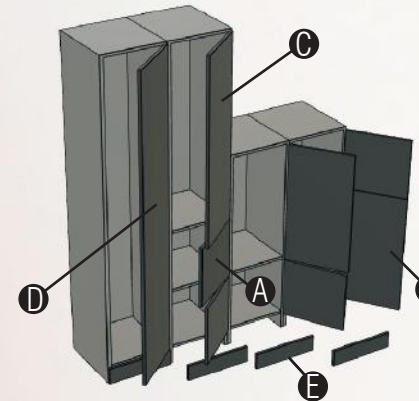

Step 2 Specify doors, drawers and plinth panels

Please note that drawers can only be specified on the bottom layer of the lockers

Shown

A	4 qty	SLK-1HD-BTR
B	2 qty	SLK-2HD-BTR
C	1 qty	SLK-3HD-BTR
D	1 qty	SLK-5HD-BTR
E	4 qty	SLK-1PT-XXX

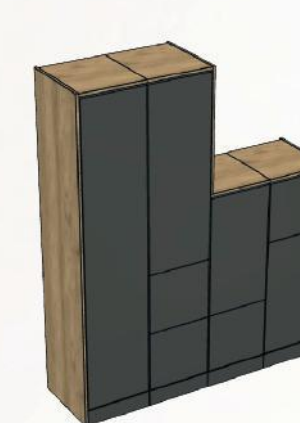
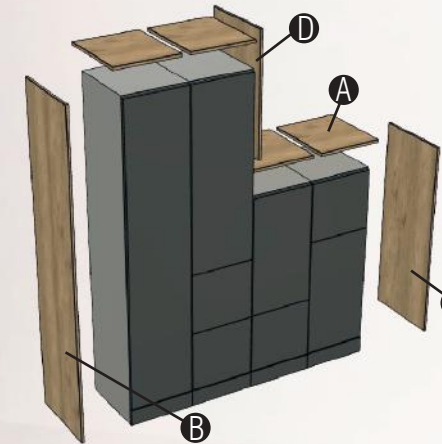

Step 3 Specify cladding panels

Where a configuration of carcasses changes height, the use of an 'intermediate' cladding panel is required (2h shown here - D). Side/top cladding panels required to cover machining details on carcass panels

Shown

A	4 qty	SLK-1FT-XXX
B	1 qty	SLK-5FS-XXX
C	1 qty	SLK-3FS-XXX
D	1 qty	SLK-2ST-XXX

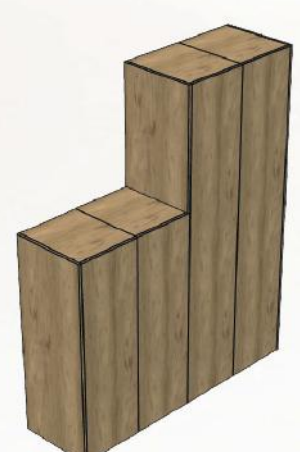
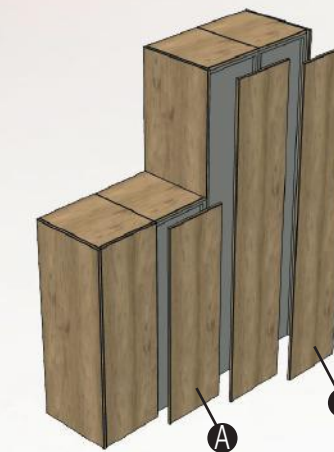

Step 4 (optional) Specify back panels

Where a configuration is placed against the wall, the use of back finishing panels may not be necessary.

Shown

A	2 qty	SLK-3FB-XXX
B	2 qty	SLK-5FB-XXX

This configuration:

Band A carcass - Dove Grey
Band B doors - Carbon Grey
Band C cladding panels - Jura Oak

Rimlocks
Combination locks
Smart RFID/code lock

Add back cladding panels:
(Band C)

Nomad carcassing

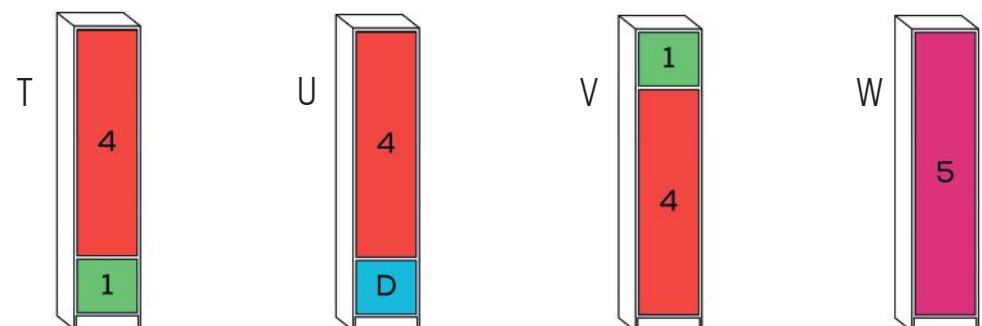
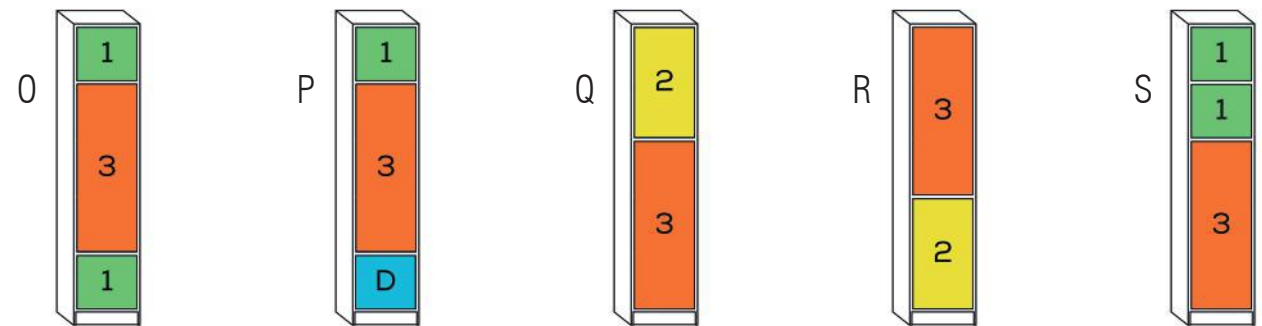
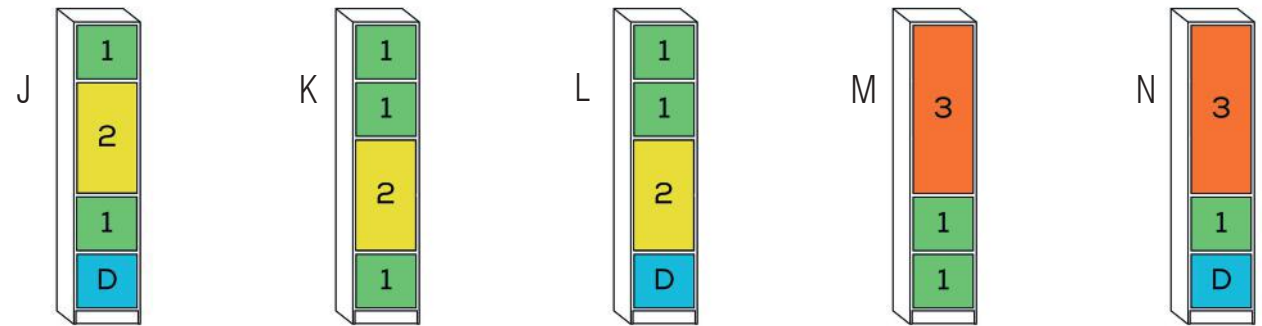
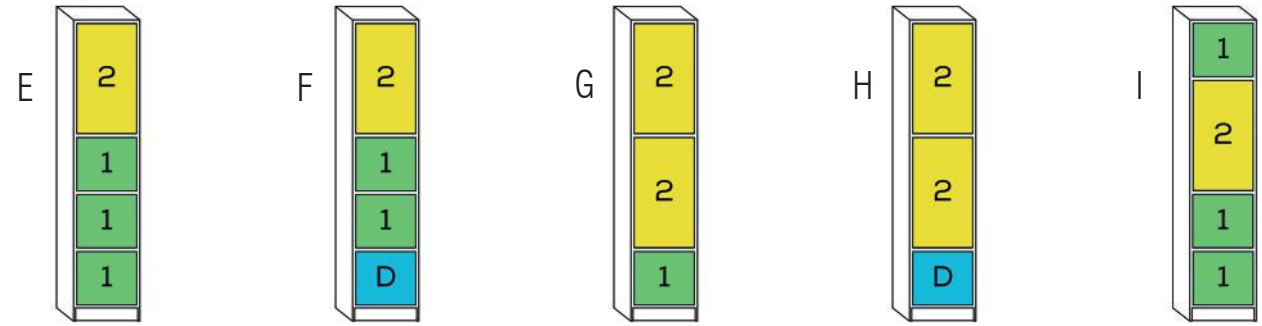
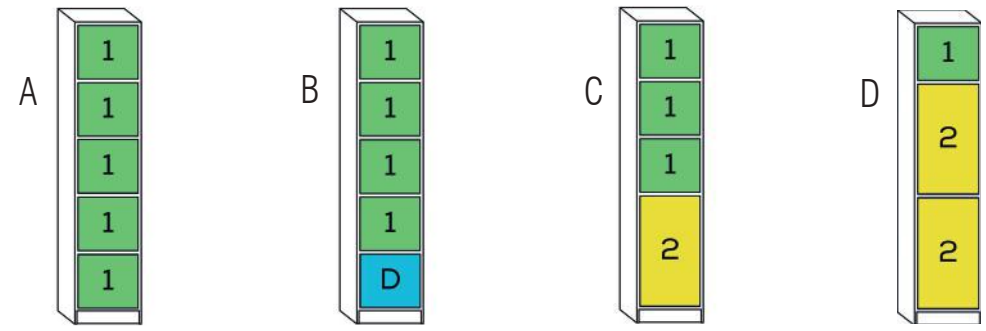

Carcass Key:
 D - Drawer
 1 - 1h compartment
 2 - 2h compartment
 3 - 3h compartment
 4 - 4h compartment
 5 - 5h compartment

Nomad carcassing

Description	Code	W	D	H
Note: Carcassing only, order doors and cladding separately				
Row 1				
A - 5h locker carcass	SLK-5HC-AXL/R	400	464	1983
B - 5h locker carcass	SLK-5HC-BXL/R	400	464	1983
C - 5h locker carcass	SLK-5HC-CXL/R	400	464	1983
D - 5h locker carcass	SLK-5HC-DXL/R	400	464	1983
Row 2				
E - 5h locker carcass	SLK-5HC-EXL/R	400	464	1983
F - 5h locker carcass	SLK-5HC-FXL/R	400	464	1983
G - 5h locker carcass	SLK-5HC-GXL/R	400	464	1983
H - 5h locker carcass	SLK-5HC-HXL/R	400	464	1983
I - 5h locker carcass	SLK-5HC-IXL/R	400	464	1983
Row 3				
J - 5h locker carcass	SLK-5HC-JXL/R	400	464	1983
K - 5h locker carcass	SLK-5HC-KXL/R	400	464	1983
L - 5h locker carcass	SLK-5HC-LXL/R	400	464	1983
M - 5h locker carcass	SLK-5HC-MXL/R	400	464	1983
N - 5h locker carcass	SLK-5HC-NXL/R	400	464	1983
Row 4				
O - 5h locker carcass	SLK-5HC-OXL/R	400	464	1983
P - 5h locker carcass	SLK-5HC-PXL/R	400	464	1983
Q - 5h locker carcass	SLK-5HC-QXL/R	400	464	1983
R - 5h locker carcass	SLK-5HC-RXL/R	400	464	1983
S - 5h locker carcass	SLK-5HC-SXL/R	400	464	1983
Row 5				
T - 5h locker carcass	SLK-5HC-TXL/R	400	464	1983
U - 5h locker carcass	SLK-5HC-UXL/R	400	464	1983
V - 5h locker carcass	SLK-5HC-VXL/R	400	464	1983
W - 5h locker carcass	SLK-5HC-WXL/R	400	464	1983

Nomad carcassing

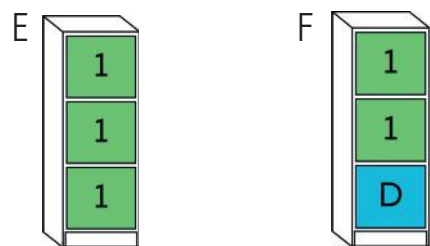
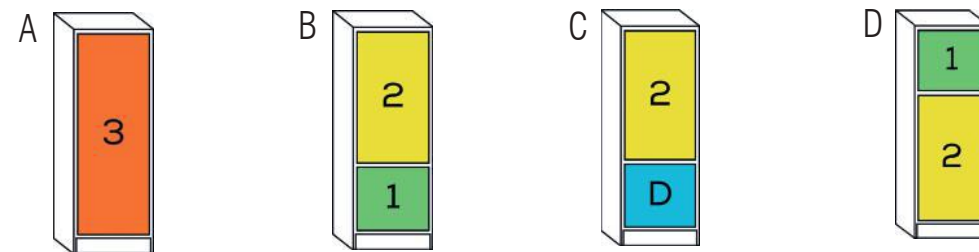
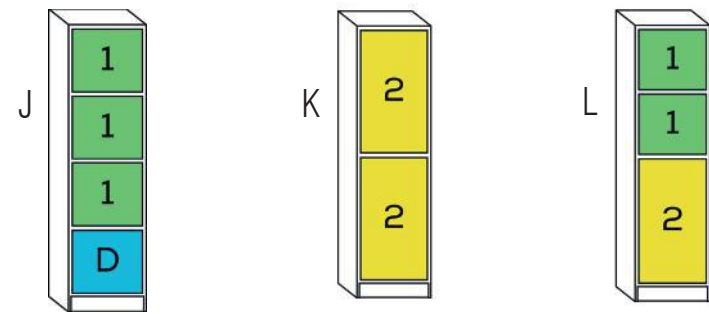
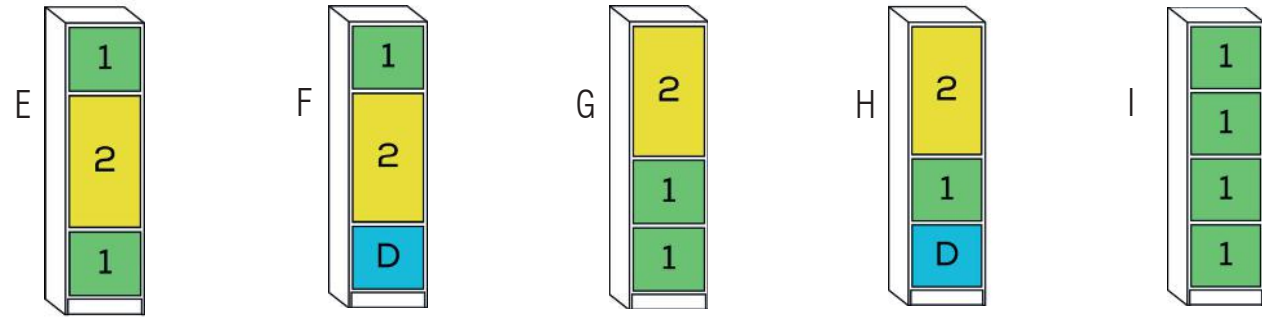
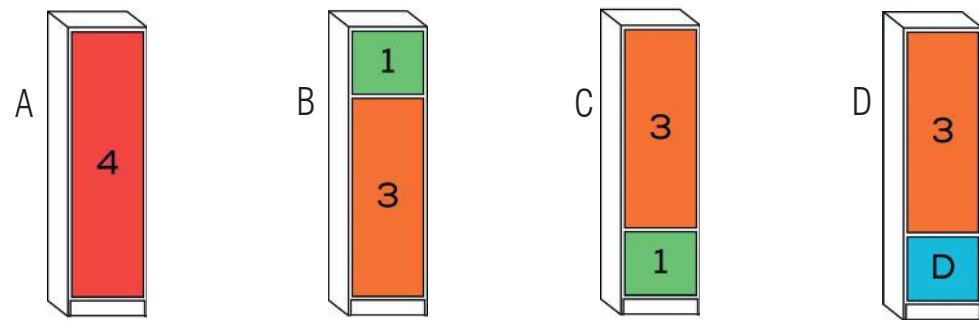

Carcass Key:
 D - Drawer
 1 - 1h compartment
 2 - 2h compartment
 3 - 3h compartment
 4 - 4h compartment

Nomad carcassing

Description	Code	W	D	H
Note: Carcassing only, order doors and cladding separately				
Row 1				
A - 4h locker carcass	SLK-4HC-AXL/R	400	464	1610
B - 4h locker carcass	SLK-4HC-BXL/R	400	464	1610
C - 4h locker carcass	SLK-4HC-CXL/R	400	464	1610
D - 4h locker carcass	SLK-4HC-DXL/R	400	464	1610
Row 2				
E - 4h locker carcass	SLK-4HC-EXL/R	400	464	1610
F - 4h locker carcass	SLK-4HC-FXL/R	400	464	1610
G - 4h locker carcass	SLK-4HC-GXL/R	400	464	1610
H - 4h locker carcass	SLK-4HC-HXL/R	400	464	1610
I - 4h locker carcass	SLK-4HC-IXL/R	400	464	1610
Row 3				
J - 4h locker carcass	SLK-4HC-JXL/R	400	464	1610
K - 4h locker carcass	SLK-4HC-KXL/R	400	464	1610
L - 4h locker carcass	SLK-4HC-LXL/R	400	464	1610
Row 4				
A - 3h locker carcass	SLK-3HC-AXL/R	400	464	1237
B - 3h locker carcass	SLK-3HC-BXL/R	400	464	1237
C - 3h locker carcass	SLK-3HC-CXL/R	400	464	1237
D - 3h locker carcass	SLK-3HC-DXL/R	400	464	1237
Row 5				
E - 3h locker carcass	SLK-3HC-EXL/R	400	464	1237
F - 3h locker carcass	SLK-3HC-FXL/R	400	464	1237

Nomad carcassing

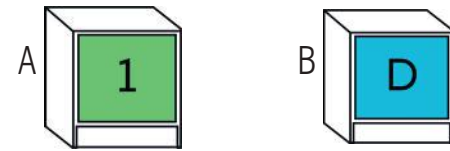
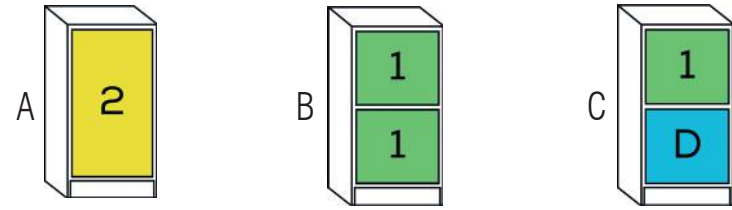

Carcass Key:

- D - Drawer
- 1 - 1h compartment
- 2 - 2h compartment

This configuration:

- Band A carcass - Pebble Grey
- Band A doors - Pebble Grey
- Band A drawers - Dove Grey
- Band B cladding panels - Soft Black

Rimlocks (shown)
Combination locks

Add back cladding panels:
(Band B)



Nomad carcassing

Description	Code	W	D	H
Note: Carcassing only, order doors and cladding separately				
Row 1				
A - 2h locker carcass	SLK-2HC-AXL/R	400	464	864
B - 2h locker carcass	SLK-2HC-BXL/R	400	464	864
C - 2h locker carcass	SLK-2HC-CXL/R	400	464	864
Row 2				
A - 1h locker carcass	SLK-1HC-AXL/R	400	464	491
B - 1h locker carcass	SLK-1HC-BXL/R	400	464	491



This configuration:

- Band B carcass - Soft Black
- Band A/C doors - Soft Black/Jura Oak
- Band B cladding panels - Soft Black

Rimlocks
Combination locks
Smart RFID/code lock (shown)

Add back cladding panels:
(Band B)

Nomad carcass dimensions

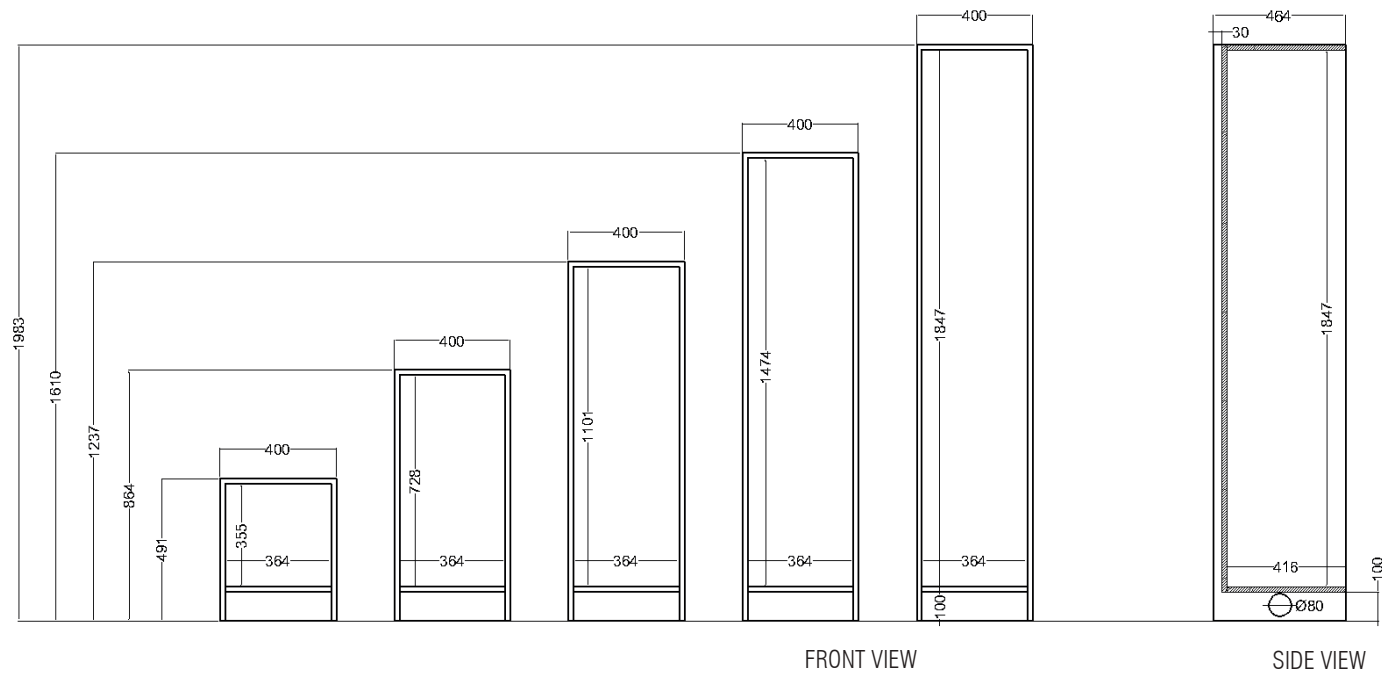

Front view showing internal and external dimensions of 1h-5h carcasses *without* finishing panels.

Cutaway showing internal depth, overall depth and 30mm cavity for cables or scribing over skirting boards.

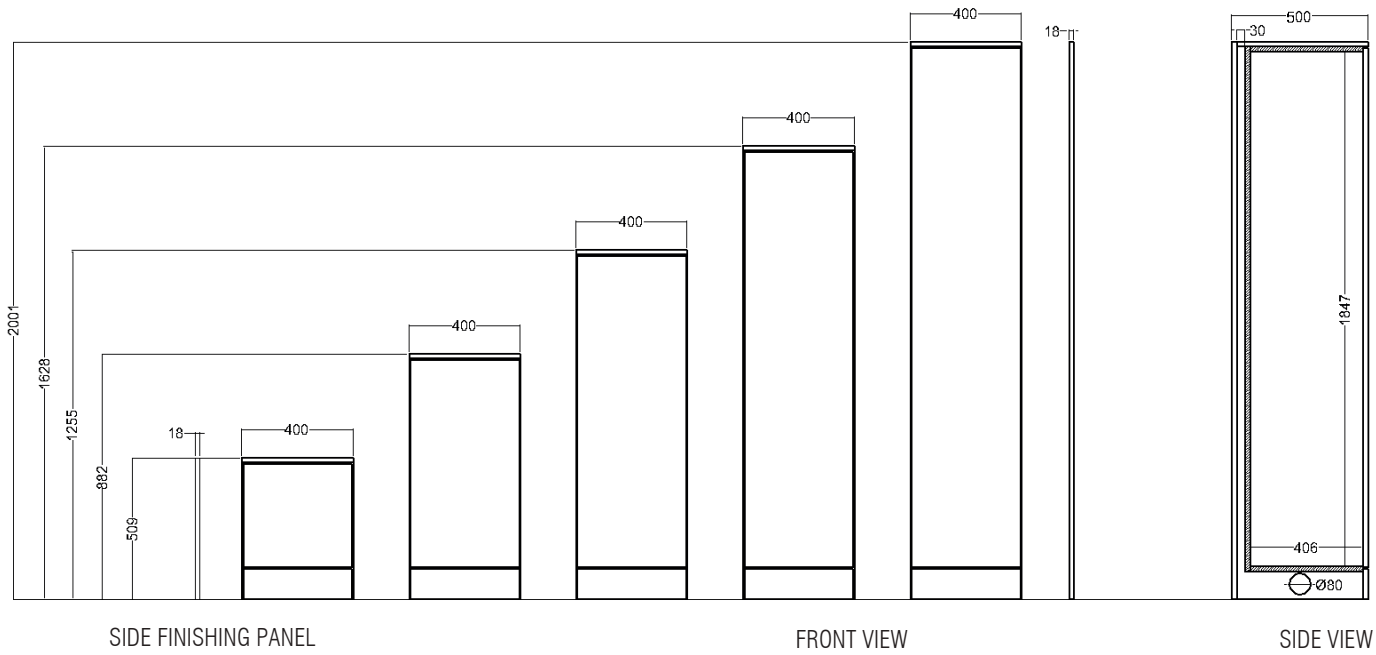

Side finishing panels will add an additional 36mm overall width to the run of lockers (18mm either side).

Front view showing external dimensions of 1h-5h carcasses *with* finishing panels and doors / plinths installed.

Cutaway showing internal depth, overall depth and 30mm cavity for cables with finishing panels and doors installed.

Nomad carcass dimensions

This configuration (right):

- Band A carcass - White
- Band A/B doors - White/Maple
- Band A Drawers - White
- Band A cladding panels - White Multiplex

- Rimlocks
- Combination locks (shown)

Add back cladding panels: (Band A)



This configuration (below):

- Band A carcass - Dove Grey
- Band B doors - Carbon Grey
- Band B cladding panels - Sorrento Walnut

- Rimlocks
- Combination locks (shown)
- Smart RFID/code lock

Add back cladding panels: (Band B)



Nomad doors & drawers

Description	Code	W	D	H
Note: If ordering mixed finish doors, please provide a layout diagram otherwise doors will be sent loose to be fitted on site.				
1h Door RH shown				
Rimlock	SLK-1HD-RML/R	394	18	368
Combination lock (shown)	SLK-1HD-CML/R	394	18	368
Burg Twinpad	SLK-1HD-BTL/R	394	18	368
Smart system				
Wired	SLK-1HD-SSL/R	394	18	368
Wireless	SLK-1HD-SNL/R	394	18	368
2h Door RH shown				
Rimlock	SLK-2HD-RML/R	394	18	741
Combination lock	SLK-2HD-CML/R	394	18	741
Burg Twinpad (shown)	SLK-2HD-BTL/R	394	18	741
Smart system				
Wired	SLK-2HD-SSL/R	394	18	741
Wireless	SLK-2HD-SNL/R	394	18	741
3h Door RH shown				
Rimlock (shown)	SLK-3HD-RML/R	394	18	1114
Combination lock	SLK-3HD-CML/R	394	18	1114
Burg Twinpad	SLK-3HD-BTL/R	394	18	1114
Smart system				
Wired	SLK-3HD-SSL/R	394	18	1114
Wireless	SLK-3HD-SNL/R	394	18	1114
4h Door RH shown				
Rimlock	SLK-4HD-RML/R	394	18	1487
Combination lock (shown)	SLK-4HD-CML/R	394	18	1487
Burg Twinpad	SLK-4HD-BTL/R	394	18	1487
Smart system				
Wired	SLK-4HD-SSL/R	394	18	1487
Wireless	SLK-4HD-SNL/R	394	18	1487

Nomad doors & drawers

Description	Code	W	D	H
Note: If ordering mixed finish doors, please provide a layout diagram otherwise doors will be sent loose to be fitted on site.				
5h Door RH shown				
Rimlock	SLK-5HD-RML/R	394	18	1860
Combination lock	SLK-5HD-CML/R	394	18	1860
Burg Twinpad (shown)	SLK-5HD-BTL/R	394	18	1860
Smart system				
Wired	SLK-4HD-SSL/R	394	18	1860
Wireless	SLK-4HD-SNL/R	394	18	1860
Drawer				
L/R denotes the side the lock position				
Rimlock (shown)	SLK-1DW-RML/R	394	390	250
Combination lock	SLK-1DW-CML/R	394	390	250
1w plinth panel <i>One required per carcass</i>	SLK-1PT-XXX	394	18	110
Wardrobe rail <i>Inc. brackets</i>	SLK-1WR-XXX	364	-	-



Rimlock



Combination lock



Smart RFID/code lock

Nomad carcassing

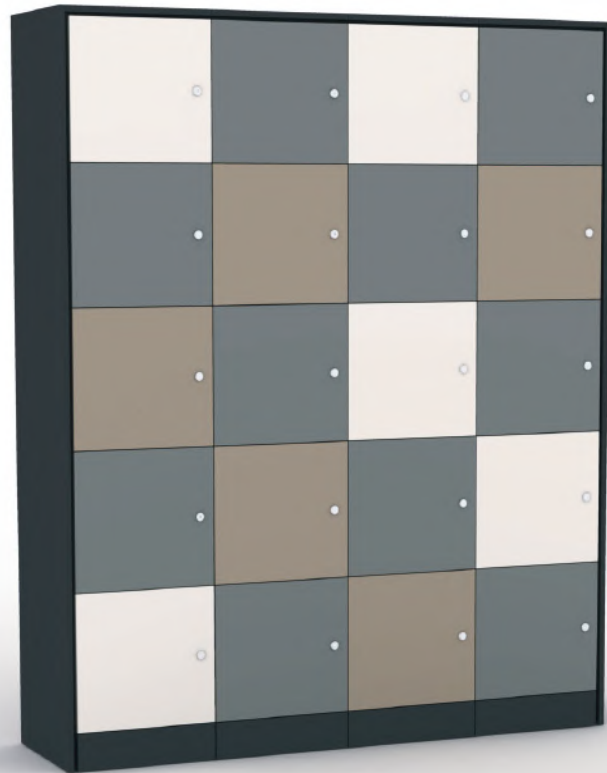

This configuration (left):

Band B carcass - Soft Black
 Band A/B doors - White/Dove Grey/
 Stone Grey
 Band B cladding panels - Soft Black

Rimlocks (shown)
 Combination locks
 Smart RFID/code lock

Add back cladding panels:
 (Band B)

This configuration (below):

Band A carcass - Dove Grey
 Band B doors - Stone Grey
 Band C cladding panels - Jura Oak







Rimlocks
 Combination locks
 Smart RFID/code lock (shown)

Add back cladding panels:
 (Band C)

The use of 2h
 intermediate cladding
 panels can be seen
 here where this
 configuration steps
 from 5h to 3h units.



Nomad cladding panels

Description	Code	W	D	H
 1w adjustable shelf <i>Includes shelf pins</i>	SLK-1AS-XXX	331	373	18
 Planter top <i>Cannot be used in conjunction with intermediate side cladding panels</i>				
 Liner not included	SLK-1PL-XXX	400	500	100
 1w top cladding panel <i>Universal across all carcass heights</i>	SLK-1FT-XXX	400	500	18
 Side cladding panel <i>Note: side cladding panels required on exposed ends to cover machining in carcass</i>				
1h side cladding panel	SLK-1FS-XXX	18	500	509
2h side cladding panel	SLK-2FS-XXX	18	500	882
3h side cladding panel	SLK-3FS-XXX	18	500	1628
4h side cladding panel	SLK-4FS-XXX	18	500	1255
5h side cladding panel (shown)	SLK-5FS-XXX	18	500	2001
 Intermediate cladding panel <i>For use between different height units</i>				
1h intermediate cladding panel (shown)	SLK-1ST-XXX	18	500	373
2h intermediate cladding panel	SLK-2ST-XXX	18	500	746
3h intermediate cladding panel	SLK-3ST-XXX	18	500	119
4h intermediate cladding panel	SLK-4ST-XXX	18	500	1492
 Removable back cladding panel <i>Optional cover for cable channels if back of locker is visible</i>				
1h back cladding panel	SLK-1FB-XXX	398	18	491
2h back cladding panel	SLK-2FB-XXX	398	18	864
3h back cladding panel	SLK-3FB-XXX	398	18	1610
4h back cladding panel	SLK-4FB-XXX	398	18	1237
5h back cladding panel	SLK-5FB-XXX	398	18	1983

Nomad cable management

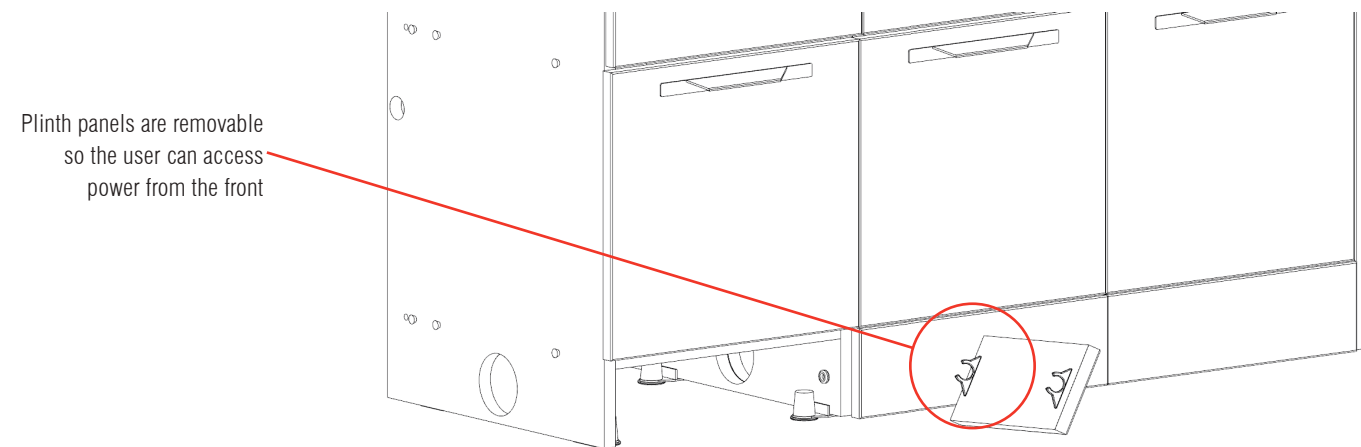
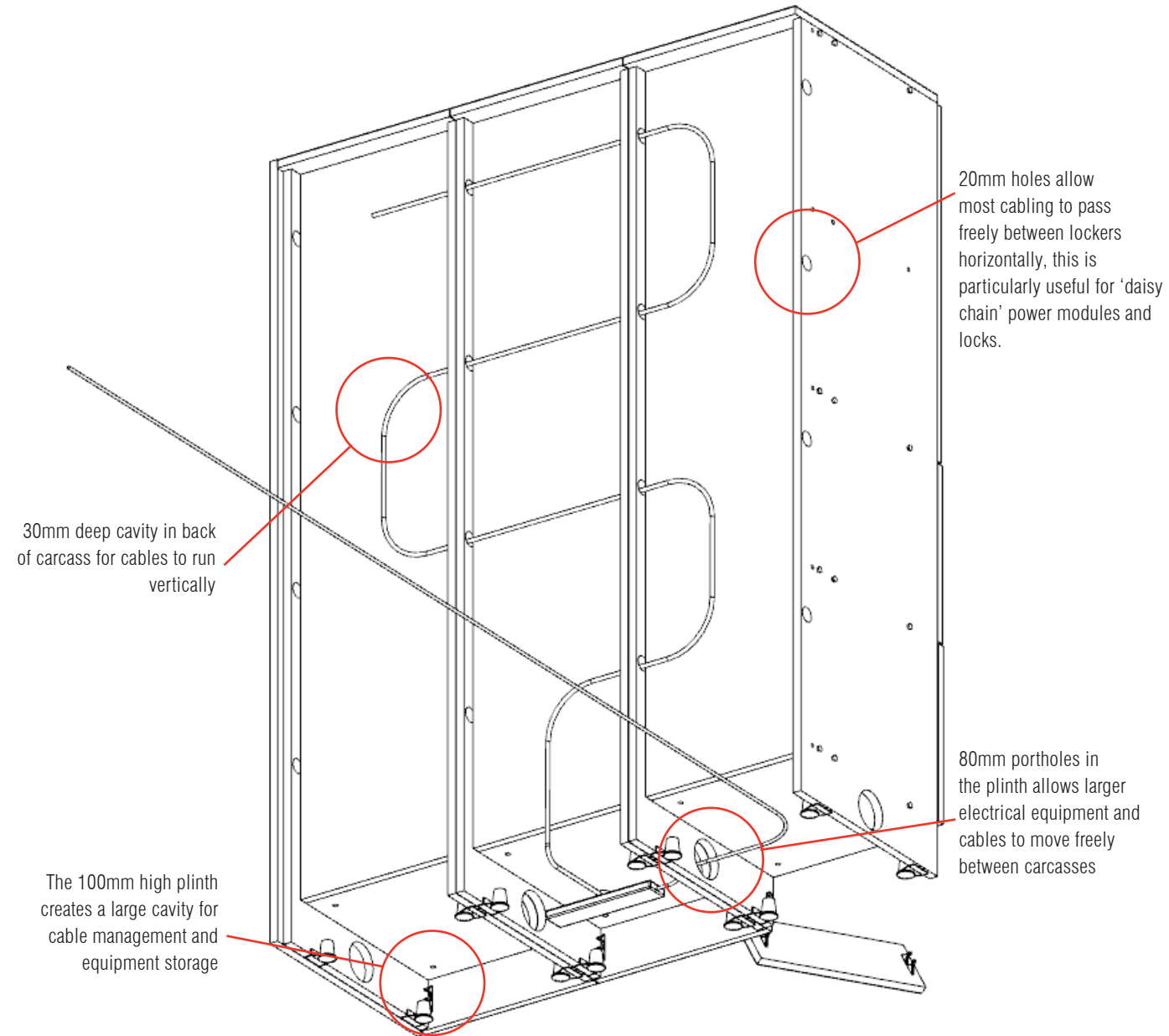

Nomad cladding panels



This configuration (above):

Band A carcass - Dove Grey
 Band B doors - Soft Black
 Band B cladding panels - Stone Grey

Rimlocks
 Combination locks (shown)
 Smart RFID/code lock

Add back cladding panels:
 (Band B)

