

RIVET RACKING LONGSPAN

Assembly Instructions

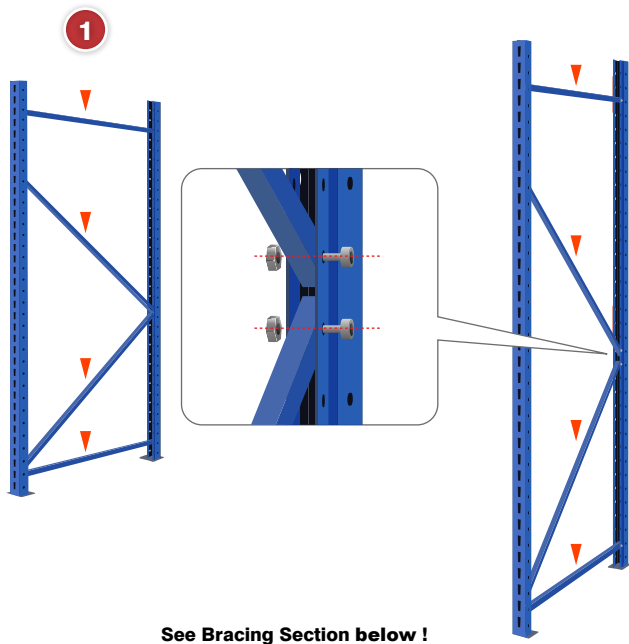

See Bracing Section below !

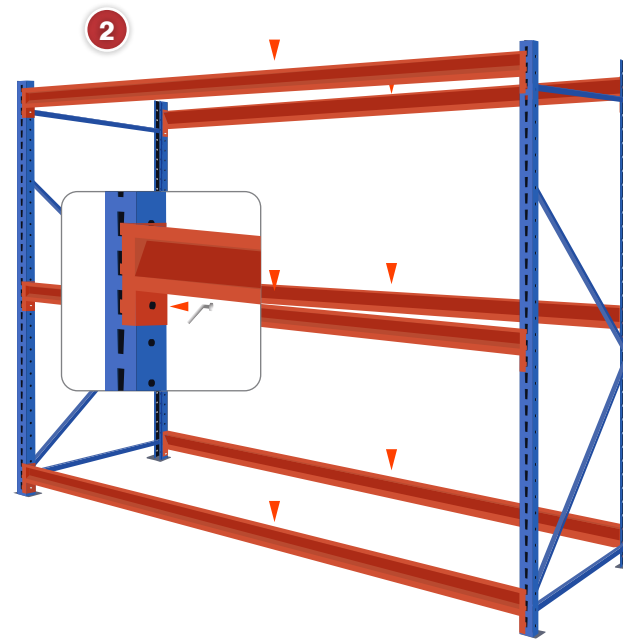

See Deck Support Section below !

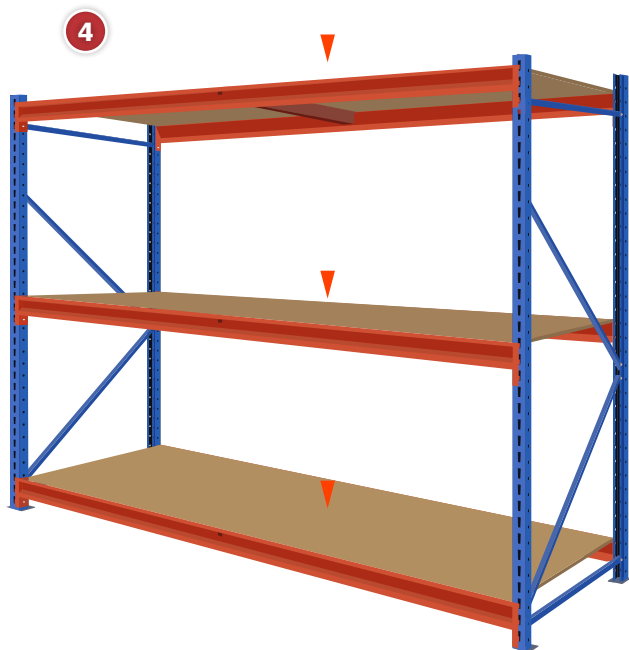

1. Check the upright is the correct way up with the metal footplate at the bottom. Position the first horizontal brace in the second hole up (76.2mm) from the footplate and fix with the M8x35mm nut and bolt provided. Position the remaining bracing as per frame layout provided (overleaf). The height of the frame will dictate the quantity of horizontal & diagonal bracings required per frame.

2. The first beam level can be positioned anywhere up to 1000mm from the floor, it is crucial that this maximum is adhered to. The system is designed for hand-loaded goods. Forklifts should not be used to load the system.

Starting from the bottom position your front and rear Z profile beams at your desired height, slot the 3 clawed beam ends into the slots in the frame and tap down with a rubber mallet. Apply safety pins to the beams you have just installed, this will aid preventing any upward force from knocking the beam levels out of the frames.

3. Deck Supports are only required in bays 610, 762, 915 and 1220mm deep, if this does not apply to you please continue to next step. Deck support quantities and positioning provided (see overleaf).

4. Once all applicable levels have been installed, the chipboard panels are ready to be placed into the beams.

First beam level position (mm)

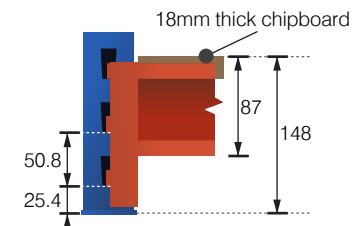

Tools Required

Rubber Mallet, 6mm Allen Key, 13mm Socket Set

Safety Precaution

Two competent people wearing **safety gloves**, **safety shoes** and **protective eyewear** are recommended to undertake the assembly.

Longspan - Deck Support Positions

— Recommended deck support position

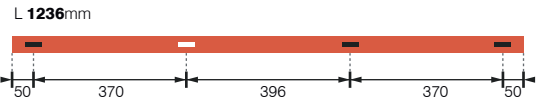
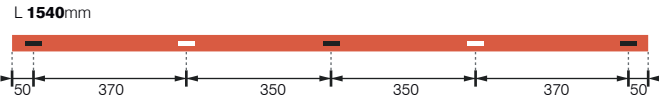
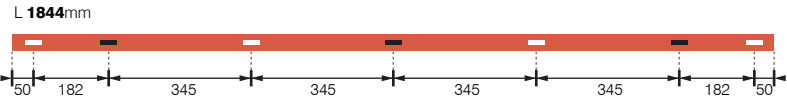
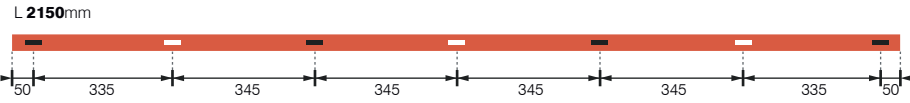
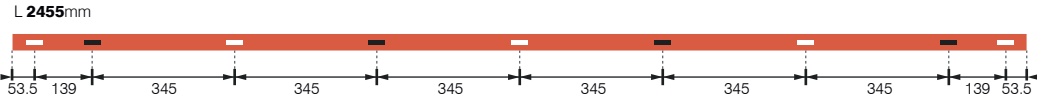

Longspan - Shelf Loadings

Longspan Shelf Capacities		
Width	Deck Supports	UDL per Shelf
1220	3	1200kg
1525	3	1000kg
1830	3	800kg
2135	4	700kg
2440	4	600kg
2745	5	440kg

First Horizontal Brace will always start in the second hole!

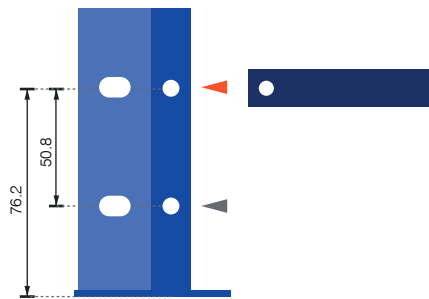

Longspan - Bracing Positions

Horizontal Brace 915mm



* Measurements given for bracing are between hole centres, **not** overall length.

